

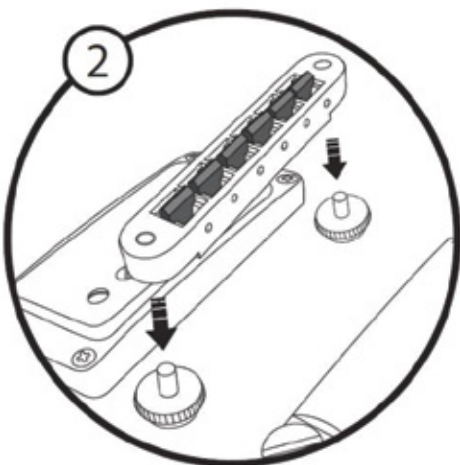

Installing a Resomax Bridge

1. First; before you remove the existing bridge, determine the correct string height, by measuring the gap between the top of the 12th fret and the bottom of the low E string.

It should be around 0.125"(3mm), or about a stack of 12 business cards if you don't have a ruler. For the high E string, the gap should be around 0.080"(2mm), or about a stack of 8 business cards.



2. Now remove the strings and remove the old bridge by lifting it off the posts. The ResoMax™ comes with posts, but in some instances you can keep using your old posts. Lower your new ResoMax™ bridge onto the posts.





3. Now install strings and tune your guitar to concert pitch. Adjust the string height by turning the thumb wheels on the bridge posts. Raise or lower the treble and bass sides of the bridge until correct string height (measured in Step 1) is achieved.

Tune the guitar to concert pitch after the adjustment and check the string height at the 12th fret. If the strings touch the bridge body behind the saddles, raise the tail piece until the strings have clearance, by turning the screws on the tail piece mounting posts.

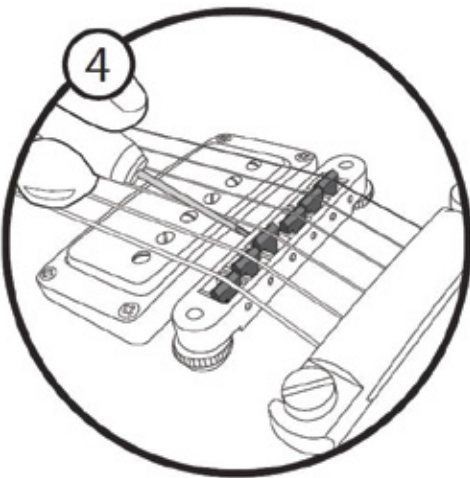

4. Set the intonation. In order for chords to play in tune all over the fretboard, each string must be correctly intonated. The note fretted at the 12th fret should match the 12th-fret harmonic. Compare the pitch of the fretted note and the harmonic (lightly touch the string right above the 12th fret and pluck).

Adjust each saddle by turning its intonation screw with a screwdriver. Shortening the string will increase the pitch of the harmonic relative to the fretted note; making the string longer will decrease the pitch. Each time you make a saddle adjustment, retune the string before comparing pitches again.

